



PHETT™ Pluggable Hybrid Electrical Terminal Truck

*The PHETT™ is the newest technology
in Diesel/Electric Hybrids.*

With the PHETT™, The FUTURE IS NOW...

- Charge Sustaining Hybrid
- Tier 4i 40 HP Genset
- 225 HP, 3 Phase AC
Traction Motor
- 220V Single Phase 40 Amp
On Board Grid Charging
- Regenerative Braking
- 130,000 lbs. GCW
- 70,000 lbs. Planetary Axles

- 60%+ reduction in fuel consumption
- ZERO exhaust and noise emissions
in battery mode
- Lowest operational cost
- 30% Reduction in audible dB's in
Gen-Set mode
- Built on the most durable frame,
cab and platform in the industry
- Backed by over 35 year history in
innovations, design and durability



NOT A RETRO-FIT BUT A GUARANTEED OEM SOLUTION



Some items shown represent optional equipment.

Taking part in a greener world.

Standard Features

Genset	Cummins Onan Diesel 40 HP 20 kw Tier 4i
Front Axle	Dana I-160W 16,000 lbs.
Rear Axle	Sisu SRDP30S, 20.57:1 Ratio Planetary Reduction, 70,000 lbs. Terminal Rating
Wheelbase	134"
Steering	TAS 85 Hydrostatic, Power
Fifth Wheel	Holland FW35, 70,000 lbs.
Boom Lift Cylinders	5" dia., 70,000 lbs, w/15" 5th Wheel Extension
Tires	11 X 22.5 16 Ply
Exhaust	Horizontal w/Heat Shield
Paint	Cab White, Frame Black, Bumper Green, Rims White, Steps and Handrails Yellow

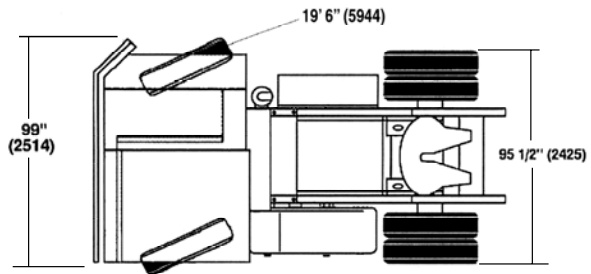
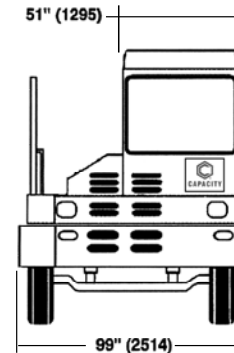
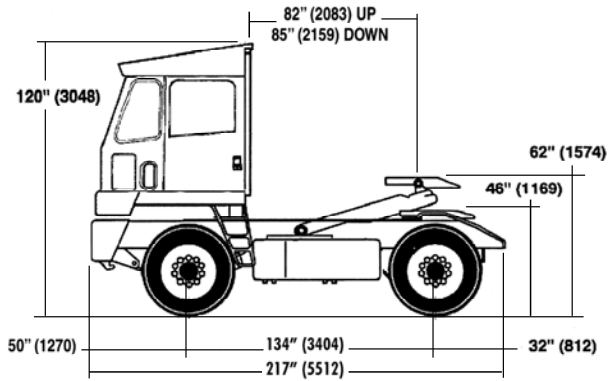

Some items shown represent optional equipment. Due to ongoing engineering improvements, Capacity reserves the right to make changes without notification. Capacity is a subsidiary of Collins Industries, Inc.

Cab Features

- VISTA Comfort Cab available in 54", 60", 66" or 72"
- Electric Cab Tilt
- Seat Belt
- Electronic Back-up Alarm
- Tinted Glass
- Level Sweep-out Cab Floor
- Gauges: Air, Fuel, Hour, Volt, Temp, Oil, Speedo, Tach & State of Charge
- Back-lit Instrument Panel with DOT ISO Icons
- High Strength Metal Dash
- Power Distribution Center (PDC) Upgrade
- Multiplexer Body Control Module
- Vehicle Electrical Center (VEC)
- Insulated Firewall Covering (engine side)
- Electric Heater/Defroster
- Overhead Storage Compartment
- Pop Open Vent (front quarter panel)
- Electric Windshield Wipers
- Engine Datalink Controlled Instruments
- Engine Dust Shield

Chassis Features

- ASTM A529 12" X 3" Reinforced Preformed Structural Steel RBM 4,500,160 in. lbs.
- 50 Degree Tapered Bumper and Deck
- 40 Gallon Diesel Fuel Tank
- Front Tow Hooks
- 3 Tank, FMVSS Style Split Brake System
- Rear Frame Guide Rails
- Automatic Brake Slack Adjusters

Distributed by: